

**Quetschkabelschuhe Gabelform**  
**Unisoliert**  
**DIN 46234**

E-Cu verzinkt

**GS Vertrieb**  
 Heinrich-Hertz-Str. 28  
 40699 Erkrath-Untersfeldhaus  
 Tel.: 0211-21032078  
 Fax: 0211-21032080  
**info@gsv-vertrieb.com**  
**www.gsv-vertrieb.com**



Querschnitt in mm <sup>2</sup>	Flanschloch für Bolzen	GSV Art.-Nr.	d	W	F	C
0,5 - 1,0mm <sup>2</sup>	M 2,5	QUG1,0-M2,5	2,70	6,00	10,80	5,0
	M 3	QUG1,0-M3	3,20	6,00	10,80	5,0
	M 3,5	QUG1,0-M3,5	3,70	6,00	10,80	5,0
	M 4	QUG1,0-M4	4,30	8,00	11,80	5,0
	M5	QUG1,0-M5	5,30	10,00	12,80	5,0
	M6	QUG1,0-M6	6,50	11,00	14,80	5,0
1,5 - 2,5mm <sup>2</sup>	M 3	QUG2,5-M3	3,20	6,00	10,80	5,0
	M 4	QUG2,5-M4	4,30	8,00	11,80	5,0
	M 5	QUG2,5-M5	5,30	10,00	13,80	5,0
	M 6	QUG2,5-M6	6,50	11,00	15,80	5,0
	M 8	QUG2,5-M8	8,40	14,00	16,80	5,0
4,0 - 6,0mm <sup>2</sup>	M 4	QUG6-M4	4,30	8,00	14,00	6,2
	M 5	QUG6-M5	5,30	10,00	15,00	6,2
	M 6	QUG6-M6	6,50	11,00	16,00	6,2
	M 8	QUG6-M8	8,40	14,00	19,00	6,2
	M 10	QUG6-M10	10,50	19,20	23,00	6,2

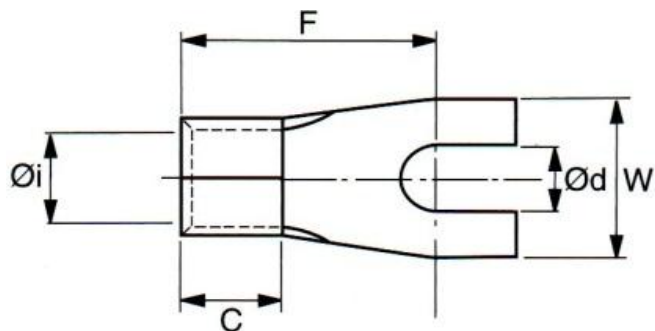

**Quetschkabelschuhe Gabelform**  
**Unisoliert**  
**DIN 46234**

E-Cu verzinkt

**GS Vertrieb**  
 Heinrich-Hertz-Str. 28  
 40699 Erkrath-Untersfeldhaus  
 Tel.: 0211-21032078  
 Fax: 0211-21032080  
[info@gsv-vertrieb.com](mailto:info@gsv-vertrieb.com)  
[www.gsv-vertrieb.com](http://www.gsv-vertrieb.com)



Querschnitt in mm <sup>2</sup>	Flanschloch für Bolzen	GSV Art.-Nr.	d	W	F	C
10,00mm <sup>2</sup>	M 5	QUG10-M5	5,50	10,50	17,00	8,3
	M 6	QUG10-M6	6,50	10,50	17,00	8,3
16,00mm <sup>2</sup>	M 5	QUG16-M5	5,50	11,00	20,00	10,0
	M 6	QUG16-M6	6,50	11,00	20,00	10,0
25,00mm <sup>2</sup>	M 5	QUG25-M5	5,50	12,00	25,00	11,0
	M 6	QUG25-M6	6,50	12,00	25,00	11,0

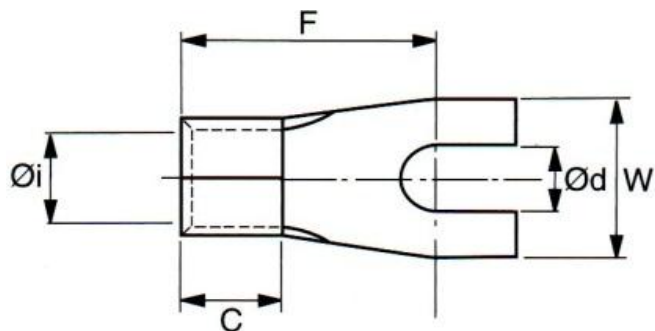

Alle Angaben OHNE Gewähr!